



## Review of Utility Company Request for New Conduit/Pole Location

**Applicant Information**

Utility Gas Electric Telephone/com  
 (circle one) Other

**Project Address**

Carter St between  
Lowell, MA Gorham St +

Reason Place fiber line to  
service 2 Pine Ave

Livingston St

Date Submitted 3/28/19  
 Review done by 3/28/19

**Sidewalk Material**

**Note: material to be replaced in kind (Concrete in full panels)**

Concrete Asphalt Other

Sidewalk Vaults present Y N  
 Work on Street under a Paving Moratorium Y N  
 Is this location within the Flood Plain? Y N  
 Are ADA requirements being met? Y N

**Comments**

This is a revised location for the conduit.

**Outcome of Review**

Approved

Approved With  
 Comments

Denied

X

Christine Clancy, P.E.  
 City Engineer

Christine Clancy



**PETITION LETTER for GRANT OF LOCATION**

To the City Council of Lowell, MA

3/6/19

**REQUESTER:**

Axis Engineering Group  
201 Boston Post Road W. Suite 100  
Marlboro, MA 01752  
Shelly Cullen  
[scullen@axisgroup.com](mailto:scullen@axisgroup.com)  
617-462-7866

For: MCI Metro Transmission Services  
82B Northside Road PO Box 600  
Charlton, MA 01507  
Tremain Fernandes  
[Tremain.k.fernandes@verizon.com](mailto:Tremain.k.fernandes@verizon.com)  
617-953-9575

**LOCATION:**

Proposed work is on Carter Street between Gorham Street and Livingston Street.

**PROPOSED WORK:**

Work is to include the installation of approximately 272' of one (1) four inch (4") Schedule 40 PVC from existing stubbed conduit to Pole 1.

## Gitschier, Angela

---

**From:** Geary, Michael  
**Sent:** Wednesday, March 27, 2019 1:04 PM  
**To:** Gitschier, Angela  
**Subject:** FW: MCI petition for Grant of Location Carter St  
**Attachments:** Lowell, MA\_2 Prince Ave\_Civil\_3-27-19\_R1.pdf

Is this a new one.

---

**From:** Shelly Cullen [<mailto:scullen@axisgroup.com>]  
**Sent:** Wednesday, March 27, 2019 12:44 PM  
**To:** Cady, Joseph  
**Cc:** Geary, Michael; Clancy, Christine  
**Subject:** RE: MCI petition for Grant of Location Carter St

Joe/Christine/Michael,  
See attached. This might make more sense. Please let me know as soon as possible so we can get on the agenda for a Grant of Location.  
THANKS, Shelly

Shelly Cullen  
Fiber Engineer  
617-462-7866



**From:** Shelly Cullen  
**Sent:** Wednesday, March 27, 2019 11:55 AM  
**To:** 'Cady, Joseph' <[JCady@lowellma.gov](mailto:JCady@lowellma.gov)>  
**Cc:** 'mgeary@lowellma.gov' <[mgeary@lowellma.gov](mailto:mgeary@lowellma.gov)>; 'cclancy@lowellma.gov' <[cclancy@lowellma.gov](mailto:cclancy@lowellma.gov)>  
**Subject:** RE: MCI petition for Grant of Location Carter St

Sorry Joe, I just realized there was electric further down and so it might get tight. I am going to move our running line to the north side of the street. Stay tuned, I will have it over to you asap.

Shelly Cullen  
Fiber Engineer  
617-462-7866

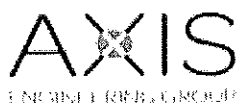

**From:** Shelly Cullen  
**Sent:** Wednesday, March 27, 2019 11:49 AM  
**To:** 'Cady, Joseph' <[JCady@lowellma.gov](mailto:JCady@lowellma.gov)>  
**Cc:** 'mgeary@lowellma.gov' <[mgeary@lowellma.gov](mailto:mgeary@lowellma.gov)>; 'cclancy@lowellma.gov' <[cclancy@lowellma.gov](mailto:cclancy@lowellma.gov)>  
**Subject:** RE: MCI petition for Grant of Location Carter St

Joe,  
Attached please find our revised drawing. Per your request we moved the water line to six feet off the curb. We shouldn't have any trouble placing our conduit between the water and the curb. Please let me know if you have any questions or concerns.  
THANKS, Shelly

Shelly Cullen  
Fiber Engineer  
617-462-7866



**From:** Shelly Cullen  
**Sent:** Thursday, March 14, 2019 12:56 PM  
**To:** [mgeary@lowellma.gov](mailto:mgeary@lowellma.gov); [cclancy@lowellma.gov](mailto:cclancy@lowellma.gov)  
**Subject:** RE: MCI petition for Grant of Location Carter St

Michael/Christine,  
Can you let me know when this petition will be on the City Council agenda to request referral for a public hearing? I know I will not need to attend the first meeting but wanted to check on the status of the petition, attached again here.  
THANKS, Shelly

Shelly Cullen  
Fiber Engineer  
617-462-7866



**From:** Shelly Cullen  
**Sent:** Friday, March 8, 2019 9:59 AM  
**To:** 'mgeary@lowellma.gov' <[mgeary@lowellma.gov](mailto:mgeary@lowellma.gov)>  
**Subject:** MCI petition for Grant of Location Carter St

Michael,  
Here is an electronic version of the petition and plans for the project that MCI Metro is proposing on Carter St in Lowell. I also dropped them off upstairs in Engineering for Christine Clancy. Please let me know if you have any questions or concerns and give me an idea when you may be able to get this on the agenda for a City Council hearing.  
THANKS, Shelly

Shelly Cullen  
Fiber Engineer  
617-462-7866



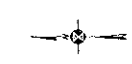
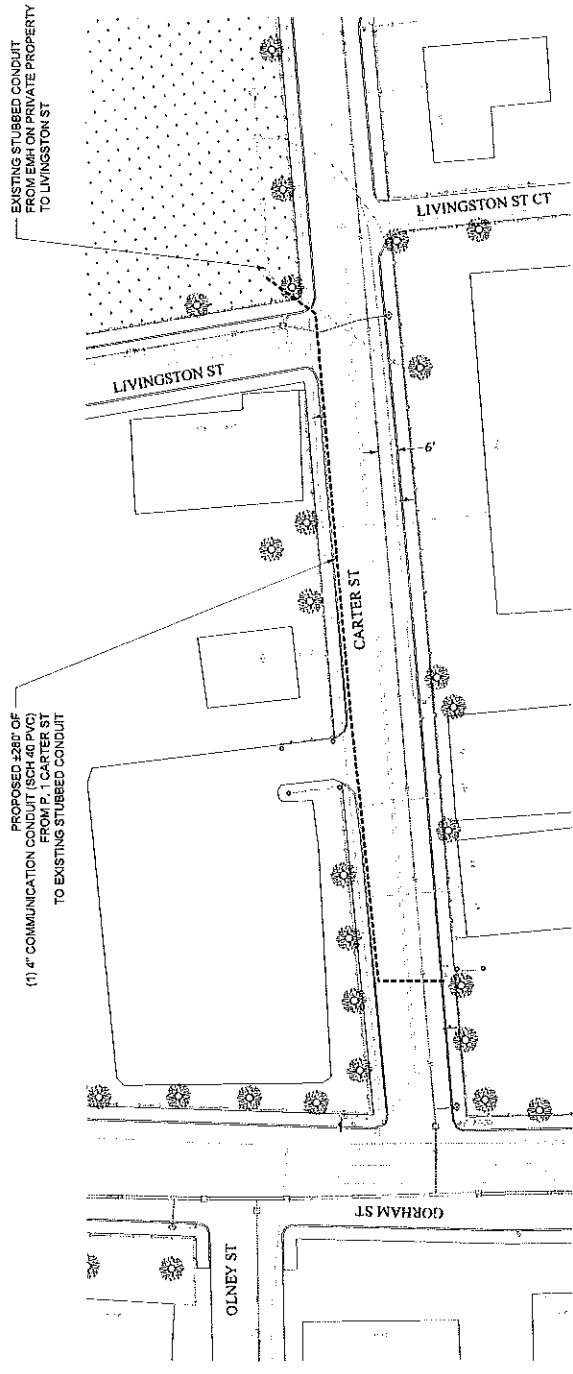

**LEGEND**

1	EXISTING UTILITY	2	PROPOSED UTILITY
3	EXISTING WATER MAIN	4	PROPOSED WATER MAIN
5	EXISTING SANITARY SEWER	6	PROPOSED SANITARY SEWER
7	EXISTING GAS	8	PROPOSED GAS
9	EXISTING TELEPHONE	10	PROPOSED TELEPHONE
11	EXISTING CABLE TV	12	PROPOSED CABLE TV
13	EXISTING FIBER OPTIC	14	PROPOSED FIBER OPTIC
15	EXISTING 4\"/>		

CALL BEFORE YOU DIG  
UNDERGROUND SERVICE ALERT  
1-800-4-A-SHIELD  
OR  
1-800-4-STATE



DATE	DATE
DESCRIPTION	DATE
1	2/11/19

PROJECT INFORMATION	
PROJECT NO.	19101
DATE	2/11/19
SCALE	AS SHOWN
DATE	2/11/19

**GENERAL NOTES**

1. THE LOCATIONS OF EXISTING UNDERGROUND UTILITIES ARE SHOWN IN AN APPROXIMATE WAY ONLY AND HAVE NOT BEEN INDEPENDENTLY VERIFIED BY THE OWNER OR ITS REPRESENTATIVE. THE CONTRACTOR SHALL DETERMINE THE EXACT LOCATION OF ALL EXISTING UTILITIES BEFORE COMMENCING WORK, AND SHALL BE FULLY RESPONSIBLE FOR ANY AND ALL DAMAGES WHICH MIGHT BE OCCASIONED BY THE CONTRACTOR'S FAILURE TO EXACTLY LOCATE AND PRESERVE ANY AND ALL UNDERGROUND UTILITIES.
2. WHERE AN EXISTING UTILITY IS FOUND, TO CONNECT WITH THE PROPOSED WORK, THE LOCATION, ELEVATION AND SIZE OF THE UTILITY SHALL BE ACCURATELY DETERMINED WITHOUT DELAY BY THE CONTRACTOR, AND THE INFORMATION FURNISHED TO THE ENGINEER FOR RESOLUTION OF THE CONFLICT.
3. THE CONTRACTOR SHOULD MAINTAIN A SEPARATION OF 18 INCHES MIN. WHEN CROSSING EXISTING WATER FACILITIES.
4. THE CONTRACTOR SHALL MAKE ALL ARRANGEMENTS FOR THE ALTERATION AND ADJUSTMENT OF GAS, ELECTRIC, TELEPHONE AND ANY OTHER PRIVATE UTILITIES BY THE UTILITY COMPANY.
5. THE CONTRACTOR SHALL NOT DISTURB PUBLIC TREES AND SHRUBS.
6. AREAS OUTSIDE THE LIMITS OF PROPOSED WORK DISTURBED BY THE CONTRACTOR'S OPERATIONS SHALL BE RESTORED BY THE CONTRACTOR TO THEIR ORIGINAL CONDITION AT NO EXPENSE TO THE OWNER.
7. THE CONTRACTOR SHALL BE RESPONSIBLE FOR PLACING AND MAINTAINING TEMPORARY RESURFACING AND/OR PLATING FOR ALL EXCAVATIONS IN PAVED STREETS AND SIDEWALKS UNTIL PERMANENT RESURFACING IS COMPLETE.
8. JOINTS BETWEEN NEW BITUMINOUS CONCRETE ROADWAY PAVEMENT AND SAW CUT EXISTING PAVEMENT SHALL BE SEALED WITH BITUMEN AND BACK SANDED.
9. THE CONTRACTOR SHALL PROTECT AND SUPPORT ALL EXISTING UTILITY LINES THAT BECOME EXPOSED DUE TO EXCAVATION REQUIRED TO INSTALL THE PROPOSED CONDUIT.
10. THE CONTRACTOR SHALL REPLACE ALL DISTURBED TRAFFIC SIGNAL LOOP DETECTORS TO GOOD WORKING CONDITION AS REQUIRED BY THE LATEST STANDARDS OF THE MUNICIPAL TRAFFIC DEPARTMENT.
11. ALL EXISTING STATE, COUNTY, CITY, AND TOWN LOCATION LINES AND PRIVATE PROPERTY LINES HAVE BEEN ESTABLISHED FROM AVAILABLE INFORMATION AND THEIR EXACT LOCATION ARE NOT GUARANTEED.
12. THE CONTRACTOR SHALL REPLACE ALL PAVEMENT MARKINGS IN THEIR ENTIRETY THAT HAVE BEEN DAMAGED BY TRENCH EXCAVATION OR OPERATIONS OF THE CONTRACTOR WITH SIMILAR COLOR AND SIZE THERMOPLASTIC MARKINGS.

\* - ITEMS SHOWN ON UTILITY RECORDS, BUT NOT FOUND IN FIELD.  
 ~ - ITEMS FOUND IN FIELD, BUT NOT IN UTILITY RECORDS.

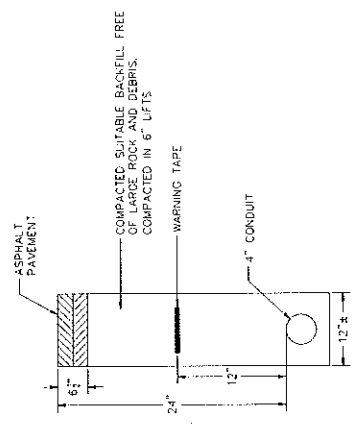

**ROADWAY PATCH AND DUCT BANK INSTALLATION DETAIL**  
N.T.S.

**TRENCH DETAIL NOTES:**

1. 24" MAXIMUM FROM TOP OF CONDUIT TO SURFACE
2. 12" FROM TOP OF CONDUIT TO METALLIC WARNING TAPE PLACED ABOVE
3. REPAIR SIDEWALKS AND WALKWAYS WITH SAME MATERIALS AS EXISTING

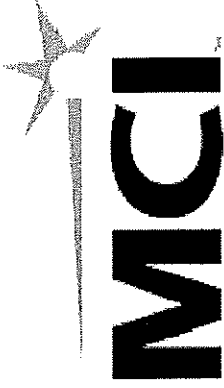

**McImetro**

ACCESS TRANSMISSION SERVICES CORP

**PROPOSED CONDUIT INSTALLATION**

**AT**

**2 PRINCE AVE**

**LOWELL, MA**



**LOCUS**  
N.T.S

**INDEX OF DRAWING**

SHEET NO.	DESCRIPTION
01	COVER SHEET
02	PROPOSED CONDUIT INSTALLATION

**AXIS**

ENGINEERING GROUP  
201 Boston Post Rd Suite 100  
Marlborough, MA 01752  
(774) 555-2524 [www.axisgroup.com](http://www.axisgroup.com)